



LE FONTEVAL – REF: 389 143

COMMON SPECIFICATIONS INSTRUCTIONS OF INSTALLATION

TECHNICAL CHARACTERISTICS

REF: 389 143	
Dimensions (W/D/H)	45 X 67 X 75
Diameter of Outlet	153 diameter
Flue Outlet	Top or rear
Combustible Material	Wood
Recommended Fuel	Logs of 50cm Compressed Logs
Nominal kW Output	10Kw
Regulation	Manual
Loading	Front Loading
Heating Volume	130 - 330M3
Functioning time of normal run	3 hours
Weight	130kg

LINEDRAWING FOR LE FONTEVAL REF: 389143

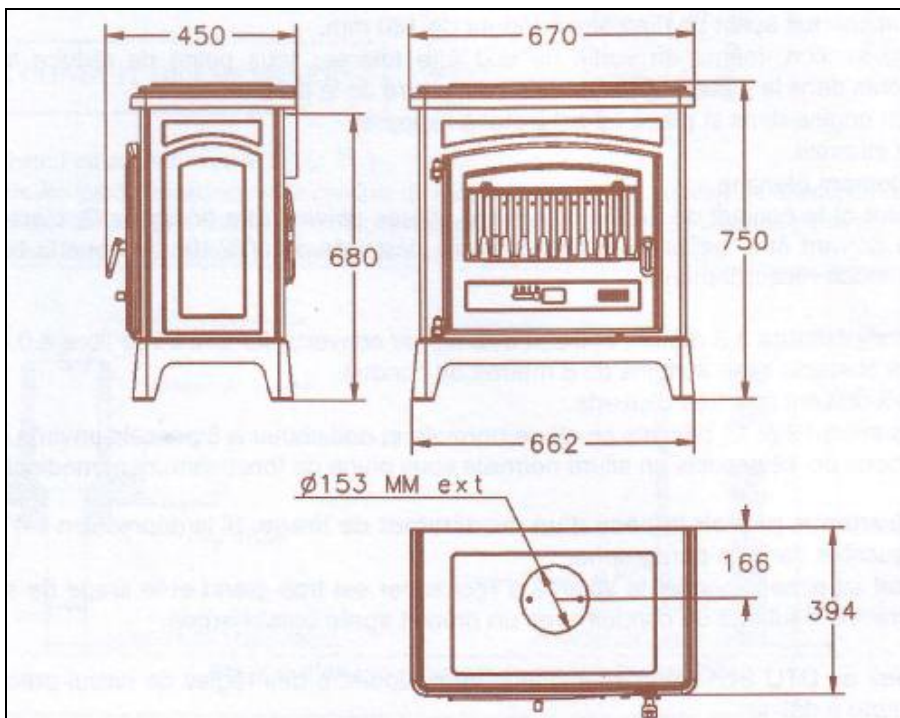

CHIMNEY & CONNECTION

The condition of the chimney flue is of prime importance. It will determine the final result: to ensure constant supply of primary air to the heater and extraction of the burned gasses. Most problems experienced are due to a defect of the chimney.

One should not compare or refer to the results provided by a previous model or make, which may have different needs of air.

- A good chimney must be built with materials of little heat transmission which do not cool down easily.
- The minimal section of the chimney for utilisation door closed is 2.5 dm², which corresponds to a diameter of 153mm. (Present regulations.)
- Not a single reduction of the flue, even at the top outlet is permissible, as it may cause a reduction of fume exhaust, which can provoke some down draught in the room when opening the door.
- The chimney must originate from the room where the heater is installed.
- The conduit to be perfectly sealed.
- The height must not be lower than 5 meters, with a reasonable upper clearance in fresh air of 0.40m, minimum above the pitch of the roof or from any other obstacle at a distance of less than 8 meters from the conduit.
- The draught should be between 1.5mm CE & 2mm CE during normal functioning, and dropping to 0.5mm CE on slow running.
- The draught must not come down below 1.2mm CE, in normal running mode.
- If the draught is too strong a draught moderator can be fitted. If the draught is insufficient, the characteristics prescribed in the paragraph for the chimney must be followed.
- If the cross-section of the chimney is too large, the volume to warm is too great and the draught will not operate normally. In that case, install a stainless steel flexible lining or other suitable lining in the chimney. The recommended size is not to be less than 153mm diameter, for a height of up to 7 meter.
- It is recommended to fit a well-sealed cleaning trap at more or less 50cm below the heater outlet.
- Before connecting, make sure that the chimney is perfectly clean. If necessary have the chimney swept.
- The appliance to be installed must conform to the D. U. T. specifications in force. The installation to be carried out by a qualified professional installer. All local and national rules are to be respected.
- If extractors are installed in the same room or space where the heater is situated they could dangerously effect the running of the heater.
- Never block the air intake of the room and install them in a manner that they cannot be obstructed. The heater takes the air from the room, therefore it is necessary to ensure sufficient air intake from outside.
- The appliances are not made to be connected to multiple chimneys.
- The factory fits the spigot at the rear of the appliance. It can be connected directly to a chimney by a horizontal pipe. It can also be connected on top, and in that case, interchange the plate and the spigot.

POSITIONING OF THE DEFLECTOR

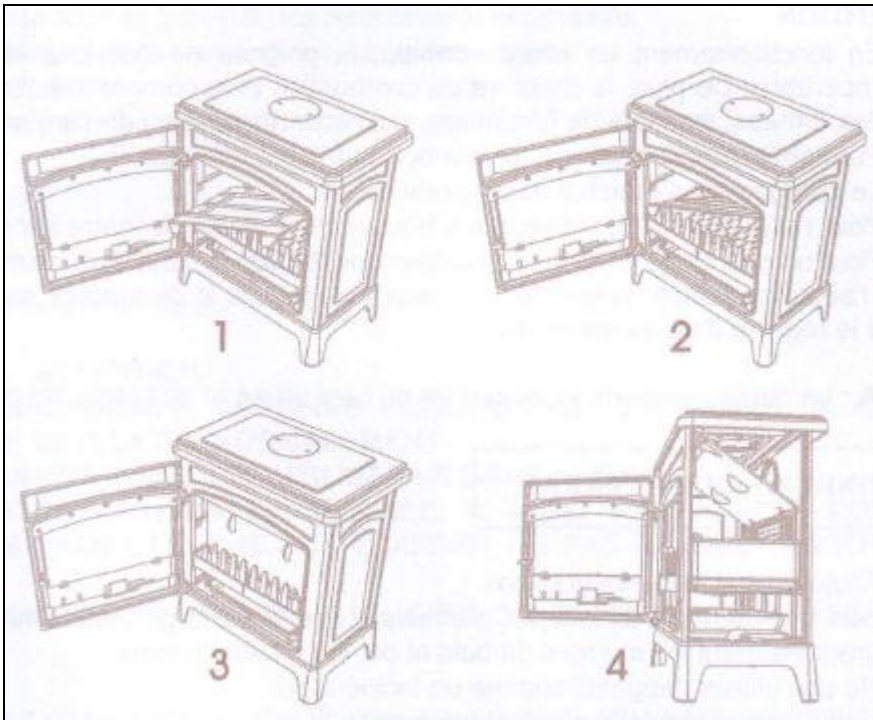

- Place the deflector diagonally through the door opening.
- Move the deflector towards the rear of the unit.
- Place at a 45deg angle, the lowest point at the rear of the unit.
- As per diagram, line up the lugs at the rear of the unit with the lots in the deflector
- Point of deflector rests on the body of the unit

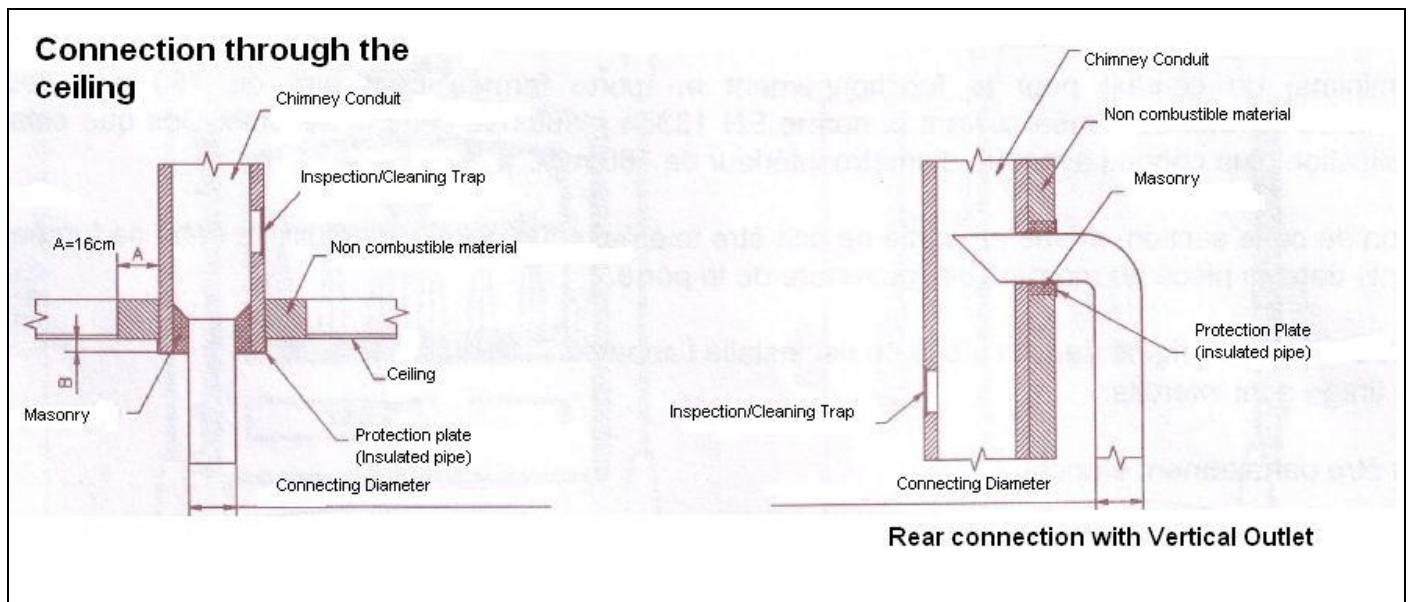

IMPORTANT

- If the floor is made of flammable materials, it is necessary to protect it with some insulation (e.g.: tiles) up to at least 40cm in front of the heater (Fig 1). Preferably use enameled flue pipes, as their resistance to corrosion is remarkable. Their length should be as short as possible, so that the heated fumes are, as it should be, used to make the draught.

- The back wall must not be made of flammable materials. If it is, it must be protected sufficiently and effectively.
- The wall on the right of the unit to be a distance of at least 60cm to allow the lateral loading of 50cm logs (enamel models only).
- The wall on the right or left to be a minimum distance of 40cm if made of flammable materials.

FUNCTIONING

A lever situated on the front door regulates the fireplace. (Marked 1 to 3)

REMARK

The secondary air comes in above the glass and keeps it clean.

LIGHTING AND OPERATION

- Completely open the air control situated on the ash-tray door.
- Load the usual lighting material, and light.
- Once the fire is burning, load the desired quantity of wood and close the flap. Regulate the unit as required.

REMARK

- During the functioning of the heater keep all material that could be altered by the heat: furniture, paper and garments, away from the heater.

ATTENTION

- While functioning normally, use the operating tool for operation (the handle will be hot.)
- While the heater is burning, keep the door closed.
- The loading can be done from the front door or lateral door.
- The regulation of the combustion is done by the engraved positions situated on the front door, above the moving flap. (Position 1 – slow, Position 2 – moderate operation, Position 3 – Normal)
- For normal running use 4 or 5 logs.
- For slow running, leave the fire until it has burned quite low, then load with one or two logs and close the flap. It is always possible to add more logs to prolong the period of combustion of the heater.

HOW TO USE THE UNIT

- Always follow instructions.
- During the first lighting of your heater use small loads so as to verify that the unit is functioning properly.
- Gradually increase the amount of logs used over a few days.
- Never use the heater as an incinerator.
- Use only the recommended fuel.
- Never use the unit with the door open.
- Don't use the heater if the glass is broken or cracked. Proceed with glass replacement before re-lighting.
- After a long period in which the unit has not been used, make sure that there are no obstructions in the chimney.

IMPORTANCE OF FUEL

- The Godin heater has a thermal output of about 70%, therefore they should give full satisfaction. The said value corresponds to the best performances.
- Remember that any heater can only give off the amount of energy contained in the fuel used.

If you feel your unit does not heat well, then:

- Either there is insufficient burning fuel or the burning fuel does not possess sufficient energy.
- Burn only dry wood, which is +/- two years old (36 months will be even better)
- In principle, all wood has the same calorific value for the same weight.
- Hard wood will be better because it is denser and often less humid.
- The humidity contained in wood alternates from 15% for dry wood up to 50% for wet wood. You will require lots of energy to evaporate the water.
- The available calories for heating are 3600 per kilo of dry wood with 15% humidity. The calories will only be 1500 per kilo for wood with 50% humidity.
- The use of wet wood, will also create condensation in the chimney, it will cause the chimney to clog up faster and can cause chimney fires.

DE-ASHING

- Once in the morning at the time of restart, and then once in the evening.
- Empty the ashtray at least every 2 to 3 days following the use of the heater.
- Never let the ashes pile up in the ashtray until they touch the grate. Consequently the grate will not cool down and will rapidly deteriorate.

CLEANING

- Sweep your chimney at least once a year. Check the condition.
- Check the heater and make sure the door seals are in a good condition. Replace if necessary.
- Clean the glass door with Godin Net. Ref.: 0009 or other suitable products.
- In case of chimney fire, call the fire brigade.

MAINTENANCE

- Have your heater checked once a year by qualified personnel.
- Never clean the glass while the unit is still hot.

ATTENTION

When lighting your heater for the first time, it is necessary to run the heater in using a low fire, so as to allow parts to expand normally. The handles are hot during normal functioning, use the operating tool.

REPLACEMENT OF PARTS

If after many years the replacing of parts becomes necessary, call your supplier or qualified GODIN installer.

Provide the model number on the plaques situated at the rear of the unit or on your guarantee card. Keep even after guarantee period has expired.

The installer will be able to supply all necessary parts and proceed with repairs,

Never use spare parts that do not originate from the GODIN factory. Never try and modify the heater without authorisation.

REPLACEMENT

We would like to remind the User, that the Manufacturers responsibility is restricted to the product as it is produced. The installation and commissioning of the unit is the responsibility of the Installer who must follow the rules and regulations in force as outlined in the manual.

So as to constantly improve the quality of products, the GODIN Co. reserves the right to modify their appliances without notice.

NOMENCLATURE ET ÉCLATÉ

N°	Nbre	Désignation	Codification	N°	Nbre	Désignation	Codification
01	1	Volet réglage air	1 4137 3142	29	1	Support foyer gauche	1 0369 389140
02	1	Verre réfractaire	1 8690 3144	30	1	Axe fermeture porte	1 2814 389143
03	1	Entretoise	1 2826 3147	31	1	Buse ronde 153 ext	1 4312 5743
04	2	Loquet de fermeture	1 2890 3147	32	1	Tampon buse 153	1 1431 5743
05	2	Fixe vitre	1 2071 3152	33	1	Boîte conduit air	1 3906 660131
06	1	Poignée porte chargement	1 2839 3242	34	1	Bouton prise air 16 mm	00001304007
07	1	Tiroir cendres	1 3315 3260 96	35	1	Cuvette à vis	00001307833
08	2	Joint plat pyrosol autocollant	-	36	2	Ecrou 6 pans 8 ZN noir	00001305951
09	1	Tresse porte foyer	1 8855 3260	37	2	Ecrou carré brut M4	00001305225
10	1	Tresse verre réfractaire	1 8826 3260	38	4	Ecrou carré brut M5	00001300269
11	1	Dessus	1 1101 3260	39	2	Goupille mecanindus 4x18 serie	00001307762
12	1	Porte foyer	1 2861 3260	40	1	Ressort 961	00001301991
13	1	Conduit supérieur air	1 4173 3260	41	2	Ressort seul RS6 Starlock	00001307254
14	1	Couvercle	1 1201 362101	42	2	Rivet acier TR 6x50	00001307987
15	3	Mentonnet fermeture	1 2146 366101	43	4	Rondelle 14x6.3x1.2	00001301784
16	1	Clé à crochet	1 4101 3720	44	2	Rondelle 16x8.2x1.5	00001300885
17	1	Ecusson	1 8501 385101	45	4	Rondelle JZC Ø8	00001300901
18	1	Tresse dessus	1 8813 3877	46	2	Vis TF M4x16 pozie	00001305966
19	2	Joint plat autocollant lg verre	1 8842 389140	47	5	Vis TF M5x10	00001301185
20	1	Conduit air secondaire	1 4112 389140	48	2	Vis TF M5x16	00001305315
21	2	Côtés	1 2317 389140	49	2	Vis TH M6x20 ZN noir	00001301240
22	1	Défecteur	1 0131 389140	50	2	Vis TH M6x30	00001304229
23	1	Derrière	1 2401 389140	51	4	Vis TH M8x20 ZN noir	00001301145
24	1	Façade	1 2101 389140	52	2	Vis TH M8x30 ZN noir	00001301241
25	2	Plaque protection côté	1 0173 3891450	53	2	Vis TH M6x40	00001307190
26	1	Protège façade	1 2175 389140	54	1	Vis TRL 4x25	00001301151
27	1	SoCLE	1 2215 389140	55	2	Vis TRL M5x20 pozie ZN noir	00001301156
28	1	Support foyer droit	1 0368 389140	56	2	Vis TRL M5x8 pozie ZN noir	00001305475

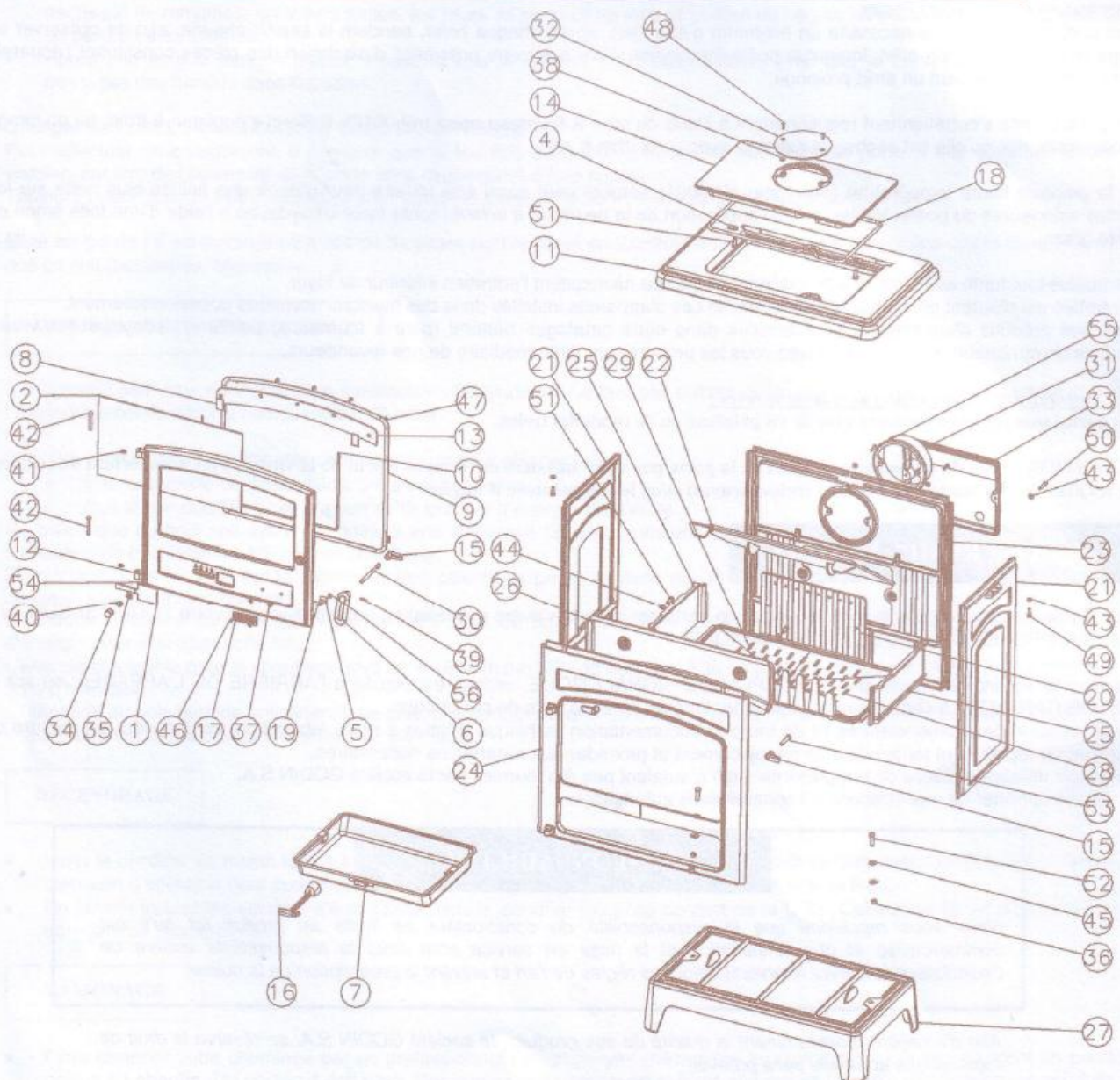

WARRANTY CONDITIONS

Any warranty is subject to: correct installation, use and maintenance of the unit.

All our appliances have a 2 year guarantee (except inserts running with wood – closed fireboxes running with wood) against any defect starting on the date of purchase. This guarantee is subject to the inspection of the installation, use and maintenance conditions described in the instruction manual supplied with the appliance.

Parts that are in direct contact with high temperatures and that could undergo distortions caused by wear and tear **are guaranteed for 1 year**. This includes:

1. Decorative panels, side panels, grills, front hearth floors, grates.
2. Guide plates, baffles, valves, ash pits, air channels and fire-bricks.
3. Articulation mechanisms (Door hinges and handles etc.)
4. Fans , thermostats for overheating of appliances equipped with blast engine
5. Temperature control elements, oven thermostats, and for fan heated gas/electric cookers
6. Burners, catalysers, burner rings for fuel appliances
7. Boilers for central heating and cooking systems for wood/coal.

Our appliances have been specially designed to facilitate replacing of these parts.

Some parts have a longer guarantee:

3 years for cast iron or steel heating body of our boilers for central heating.

Wood-burning Inserts and closed fireboxes running with wood, have a 5 year warranty (only the heating body, parts in direct contact with high temperatures and undergoing wear and tear, described above have 1 year guarantee.)

Only the parts/s that are deemed to have failed will be covered by the warranty. Any indemnity, compensatory damage, cost of labour and transportation is not included.

In cases the repair or replacement reveals to be too expensive compared to the price of the appliance, the decision to replace or to repair the appliance is to be taken by Godin after sales service only.

Parts not covered by warranty:

1. GLASS – ceramic glass can withstand temperatures of up to 750°C. The glass can only break because of a mechanical shock while using or handling the appliance.
2. Glass seals and ceramic rope seals are considered wear and tear items.

The following will invalidate any warranty:

1. Damage caused by burning fuels other than those for which the unit is intended.
2. Any defect or deterioration caused by a fall, shock, negligence or lack of supervision and maintenance.
3. Deterioration of parts caused by abnormal conditions (back draft, dampness, storm effects, pressure and depression of non conform, temperature shock etc).
4. Abnormal usage of the unit (using a unit with the door open, running it on maximum for extended periods) or abnormal usage of the appliance in conditions that are different from the conditions in our manual for which it has been designed, for example non

observation of our technical manuals (wrong electric connection, running an empty boiler etc)

5. Any defect, deterioration or accident caused by fall, shock, negligence, lack of the buyer's supervision or maintenance.
6. Any modifications or transformations made to the unit and non-compliance with installation norms.

Godin SA will not be responsible for any installation, assembly, dismantling costs and consequential removal of the appliance.

Consequently Godin SA, cannot be held responsible for any materials loss or human accidents, being a result of incorrect installation non – observing the legal provisions and regulations (for example, lack of ground connection, incorrect draft of the chimney etc...)

In order to constantly improve our products, we reserve the right to modify our appliances without prior notice. All the dimensions and specifications give are subject to variation according to technical requirements.

In case of a problem occurred during your guarantee period, please contact your retailer providing him with a copy of your bill and guarantee containing the appliances product codes, the retailers stamp, the date of the appliance installation.