



Extractor Systems

- COMMERCIAL EXTRACTORS -

Our Stainless Steel Extractor Systems are designed to extract the smoke generated by our Gas Braais and other appliances.

We manufacture various lengths of ducting, elbows, brackets and couplings, making it possible for us to supply an extractor system for almost any application, even commercial applications.

Each system is compiled individually to suit your custom needs.

Our helpful staff are always keen to help you decide on the appropriate extractor components for your specific installation.

- Available in 4 Sizes
- Designed to extract smoke generated by gas grills
- Supplied complete with a grease filter, drip tray and light-fitting
- Commercial Grade applications possible



SAFETY, STYLE & QUALITY THAT LASTS

CHAD-O-CHEF
Lifestyle products

Since 1983



Extractor Systems

- COMMERCIAL EXTRACTORS -

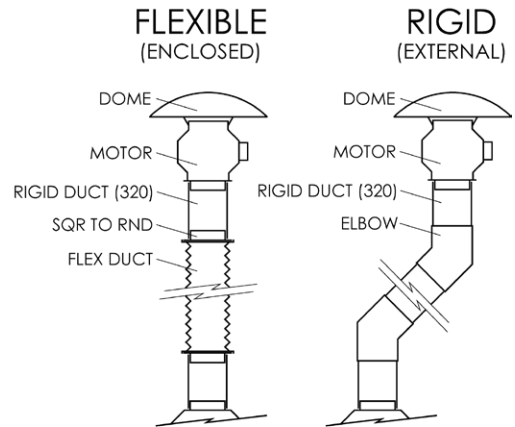
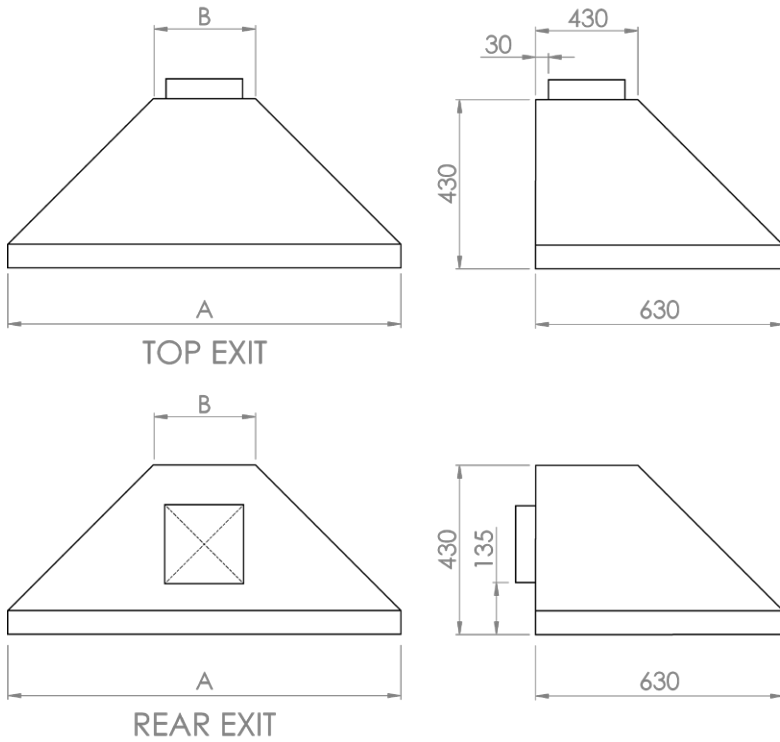

Model	A	B
1000	1000	260
1250	1250	510
1500	1500	760
1800	1800	1060

DUCTING EXIT : 200x200

INSTALLATION INSTRUCTIONS

Our Extractor Systems come in **Top Exit** and **Rear Exit** configurations and are then further customisable by **Flexible** and **Rigid** flue configurations as well, to suit any orientation and application your home might require.

Various lengths of **Rigid** stainless steel ducting and elbows, allow for applications where the extraction system is exposed to outside elements. Our **Flexible** ducting allows for cost savings in internal chimney installations, where the ducting is subject to tighter bends and will not be subjected to the elements.



CHAD-O ENGINEERING
 T: 011 668 1910/1 | F: 086 612 5431
 retail@chad-o-chef.co.za | www.chad-o-chef.co.za

